

SCHOTTKY RECTIFIERS

Features:

- High ESD capacity
- High junction temperature capability
- High frequency operation
- Low leakage current
- High surge capacity

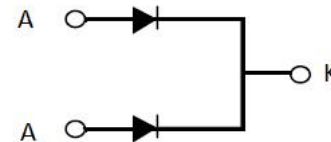
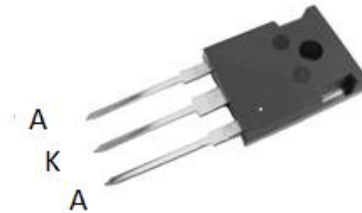

Applications:

- Switching mode power supply
- High frequency inverter circuit
- Polarity protection circuit

Product Summary	
V_R	200 V
$I_{F(AV)}$	2*10A
T_j	175 °C
$V_F(max.)$	0.950V

Absolute Maximum Ratings			
Parameter	Symbol	Values	Units
Repetitive peak reverse voltage	V_{RRM}	200	V
Continuous forward current	$I_{F(AV)}$	20	A
Single pulse forward current	I_{FSM}	200	
Operating junction	T_j	175	°C
Storage temperatures	T_{stg}	-55 to +175	°C
Peak Repetitive Reverse Surge Current	I_{RRM}	5	A

Electrical characteristics (Ta=25°C unless otherwise specified)						
Parameter	Symbol	Test Conditions	Min	Typ.	Max.	Units
Breakdown voltage Blocking voltage	V_{BR} , V_R	$I_R=100\mu A$	200			V
Forward voltage (Per Diode)	V_F	$I_F=10 A$		0.88	0.950	
		$I_F=10 A, T_j=125^\circ C$		0.750	0.900	
Reverse leakage current(Per Diode)	I_R	$V_R=V_{RRM}$			5	μA
		$T_j=125^\circ C, V_R=200V$			5	mA

Thermal characteristics

Parameter	Symbol	Typ.	Units
Junction-to-Case	$R_{\theta JC}$	0.8	$^\circ C/W$

Electrical performance (typic)

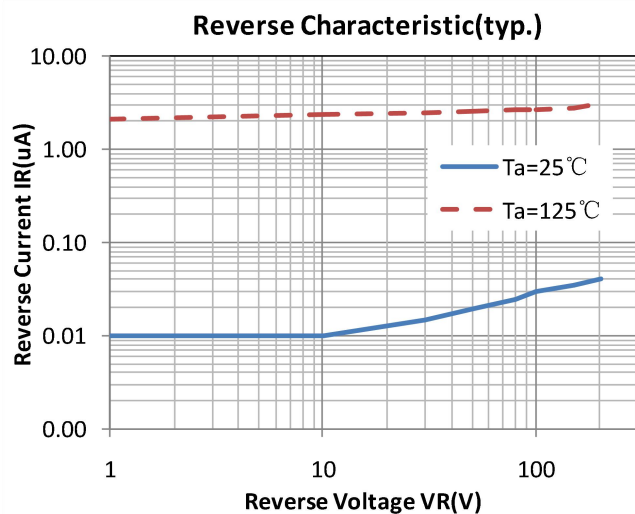
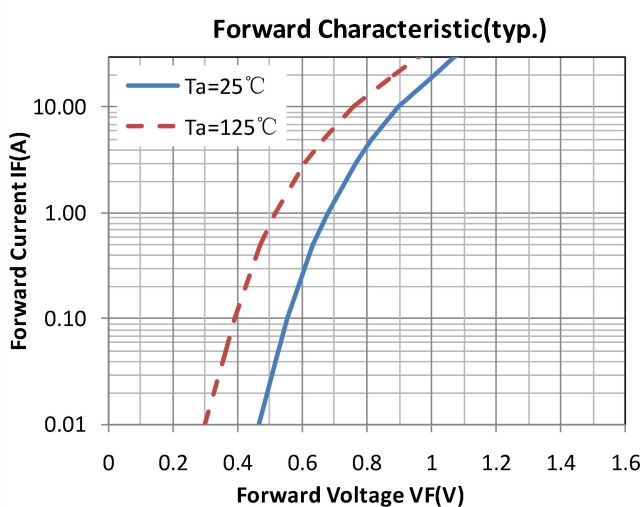

Package Information

TO-247 PACKAGE

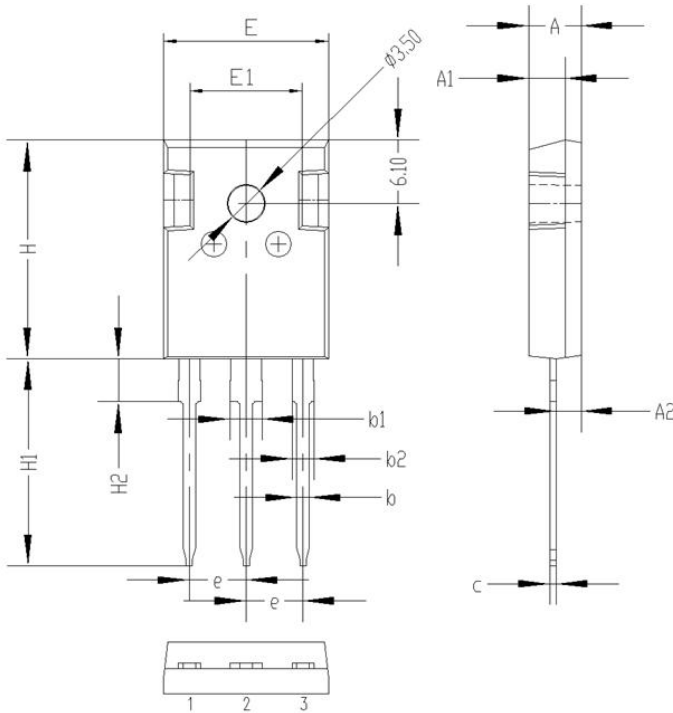

Symbol	Dimensions(millimeters)	
	Min.	Max.
A	4.80	5.20
A1	3.30	3.70
A2	2.10	2.50
b	1.00	1.40
b1	2.90	3.30
b2	1.90	2.30
c	0.40	0.80
e	5.25	5.65
E	15.6	16.0
E1	10.6	11.00
H	20.8	21.2
H1	19.4	20.4
H2	3.90	4.30
G	5.90	6.30
ΦP	3.30	3.70