

Silicon P-Channel Power MOSFET

General Description :

The HMR10P06 uses advanced trench technology and design to provide excellent $R_{DS(ON)}$ with low gate charge. It can be used in a wide variety of applications. The package form is TO-252, which accords with the RoHS standard.

V_{DSS}	-60	V
I_D	-10	A
P_D	35	W
$R_{DS(ON)type}$	140	m Ω

Features :

- $R_{DS(ON)} < 155m\Omega @ V_{GS}=10V$ (Typ140m Ω)
- High density cell design for ultra low R_{dson}
- Fully characterized avalanche voltage and current
- Excellent package for good heat dissipation

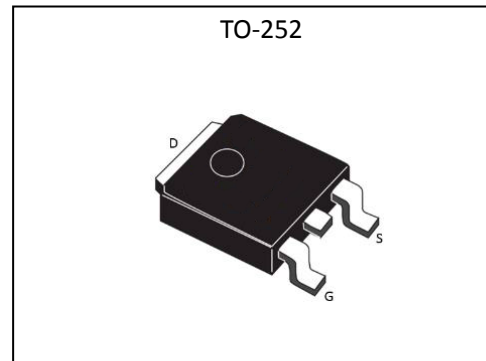

Inner Equivalent Principium Chart

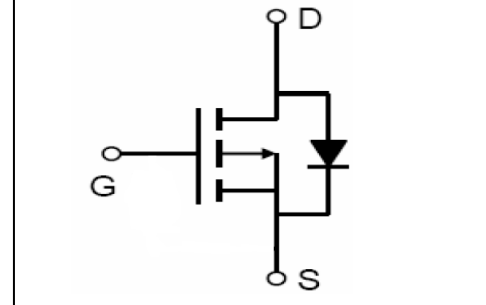

Applications :

- Power switching application
- Hard switched and high frequency circuits
- Uninterruptible power supply

Absolute ($T_c= 25^\circ C$ unless otherwise specified) :

Symbol	Parameter	Rating	Units
V_{DSS}	Drain-to-Source Voltage	-60	V
I_D	Continuous Drain Current	-10	A
I_{DM}	Pulsed Drain Current	-40	A
V_{GS}	Gate-to-Source Voltage	± 20	V
P_D	Power Dissipation	35	W
E_{AS}	Single pulse avalanche energy ^{a5}	80	mJ
T_J, T_{stg}	Operating Junction and Storage Temperature Range	150 , -55 to 150	$^\circ C$

Electrical Characteristics ($T_c = 25^\circ\text{C}$ unless otherwise specified) :

OFF Characteristics						
Symbol	Parameter	Test Conditions	Rating			Units
			Min.	Typ.	Max.	
V_{DSS}	Drain to Source Breakdown Voltage	$V_{GS}=0V, I_D=250\mu A$	-60	--	--	V
I_{DSS}	Drain to Source Leakage Current	$V_{DS}=-60V, V_{GS}=0V, T_a=25^\circ\text{C}$	--	--	1.0	μA
$I_{GSS(F)}$	Gate to Source Forward Leakage	$V_{GS}=+20V$	--	--	0.1	μA
$I_{GSS(R)}$	Gate to Source Reverse Leakage	$V_{GS}=-20V$	--	--	-0.1	μA

ON Characteristics ^{a3}						
Symbol	Parameter	Test Conditions	Rating			Units
			Min.	Typ.	Max.	
$R_{DS(ON)}$	Drain-to-Source On-Resistance	$V_{GS}=-10V, I_D=-10A$	--	140	155	$m\Omega$
$V_{GS(TH)}$	Gate Threshold Voltage	$V_{DS}=V_{GS}, I_D=250\mu A$	-1	--	-3	V

Pulse width $t_p \leq 380\mu s, \delta \leq 2\%$

Dynamic Characteristics ^{a4}						
Symbol	Parameter	Test Conditions	Rating			Units
			Min.	Typ.	Max.	
g_{fs}	Forward Transconductance	$V_{DS}=-15V, I_D=-5A$	10	--	--	S
C_{iss}	Input Capacitance	$V_{GS}=0V, V_{DS}=-25V$ $f=1.0\text{MHz}$	--	580	--	pF
C_{oss}	Output Capacitance		--	55	--	
C_{rss}	Reverse Transfer Capacitance		--	30	--	

Resistive Switching Characteristics ^{a4}						
Symbol	Parameter	Test Conditions	Rating			Units
			Min.	Typ.	Max.	
$t_{d(ON)}$	Turn-on Delay Time	$V_{DD}=-30V, I_D=-10A$ $V_{GS}=-10V, R_G=9.1\Omega$	--	8	--	ns
t_r	Rise Time		--	4	--	
$t_{d(OFF)}$	Turn-Off Delay Time		--	28	--	
t_f	Fall Time		--	5.8	--	
Q_g	Total Gate Charge	$V_{DD}=-30V, I_D=-10A$ $V_{GS}=-10V$	--	18	--	nC
Q_{gs}	Gate to Source Charge		--	3	--	
Q_{gd}	Gate to Drain ("Miller") Charge		--	7	--	

Source-Drain Diode Characteristics

Symbol	Parameter	Test Conditions	Rating			Units
			Min.	Typ.	Max.	
I_S	Continuous Source Current ^{a2} (Body Diode)		--	--	-10	A
V_{SD}	Diode Forward Voltage ^{a3}	$I_S = -10A, V_{GS} = 0V$	--	--	-1.2	V

Symbol	Parameter	Typ.	Units
$R_{\theta JC}$	Junction-to-Case ^{a2}	3.57	°C/W

^{a1} : Repetitive Rating: Pulse width limited by maximum junction temperature.

^{a2} : Surface Mounted on FR4 Board, $t \leq 10\text{sec}$.

^{a3} : Pulse Test: Pulse Width $\leq 300\mu\text{s}$, Duty Cycle $\leq 2\%$.

^{a4} : Guaranteed by design, not subject to production

^{a5} : EAS condition : $T_j = 25^\circ\text{C}, V_{DD} = -50V, V_G = -10V, L = 0.5\text{mH}, R_g = 25\Omega$

Test circuit

1) EAS Test Circuit

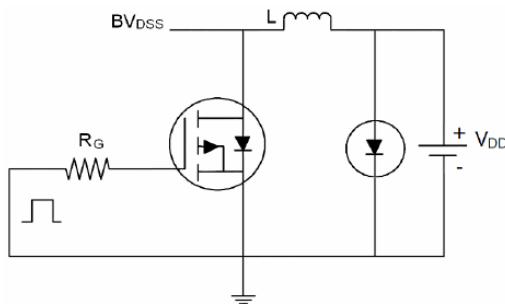

2) Gate Charge Test Circuit

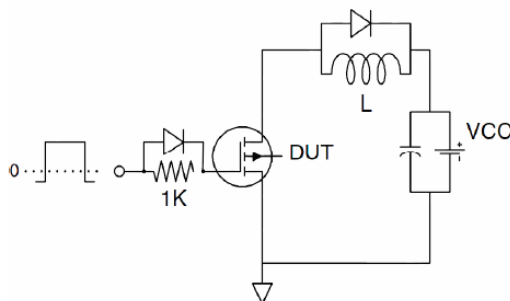

3) Switch Time Test Circuit

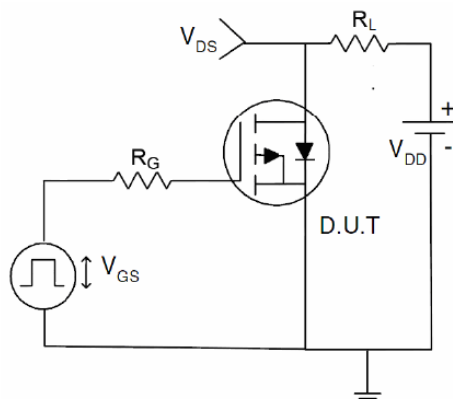

Characteristics Curve :

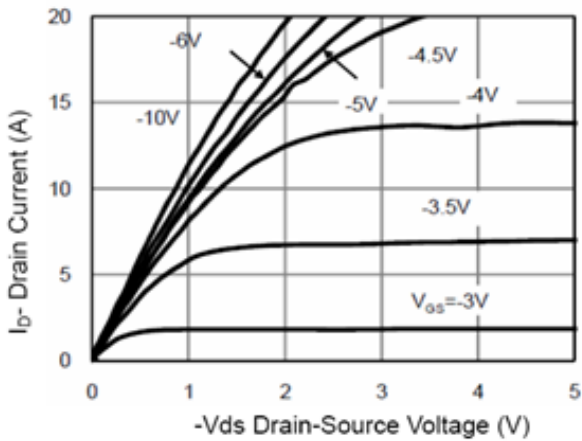

Figure 1 Output Characteristics

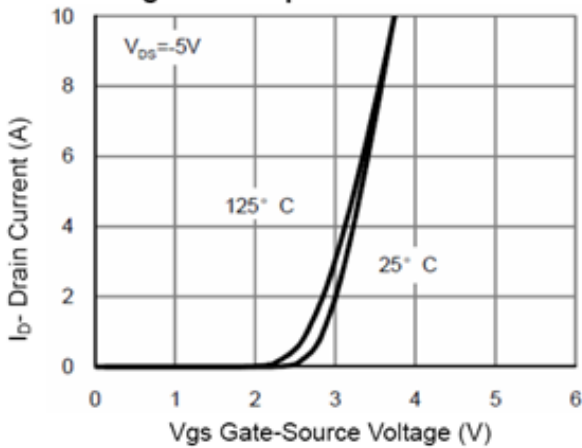

Figure 2 Transfer Characteristics

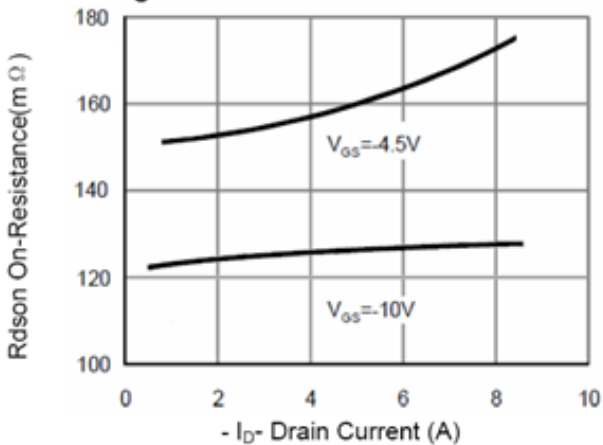

Figure 3 Rdson- Drain Current

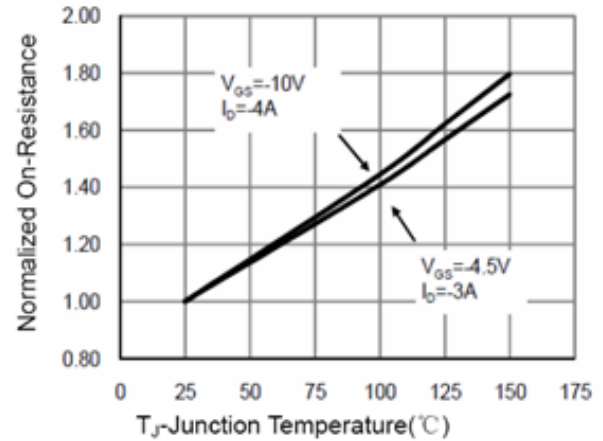

Figure 4 Rdson-Junction Temperature

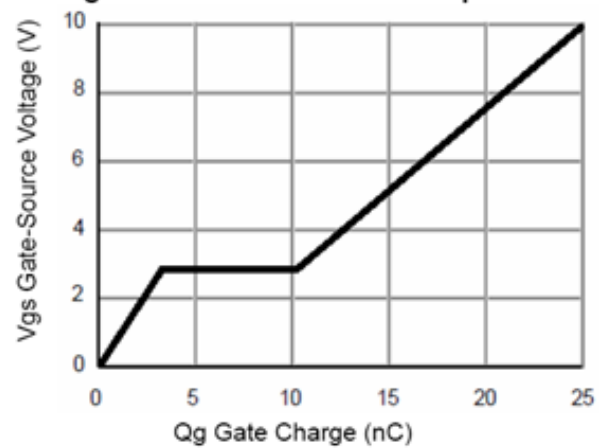

Figure 5 Gate Charge

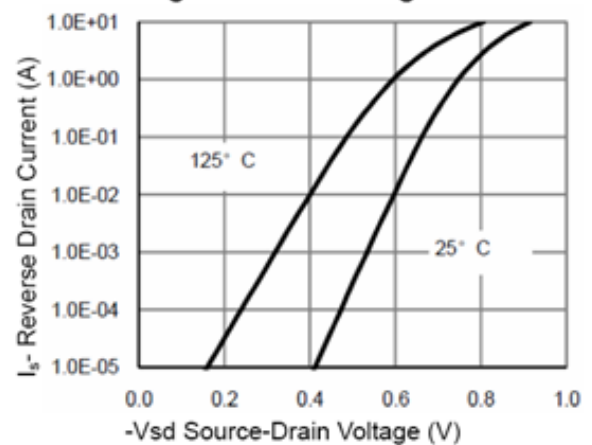

Figure 6 Source- Drain Diode Forward

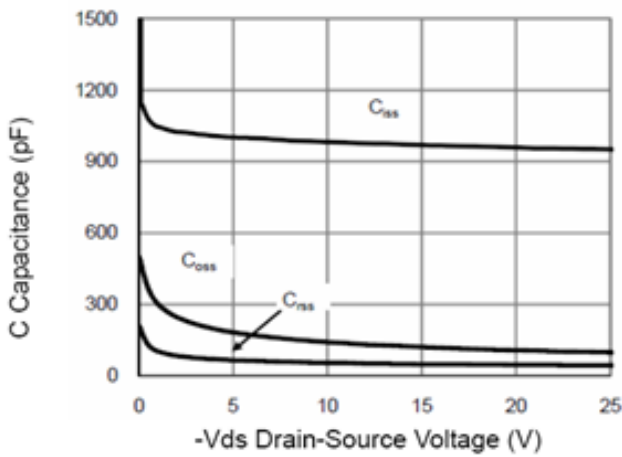

Figure 7 Capacitance vs Vds

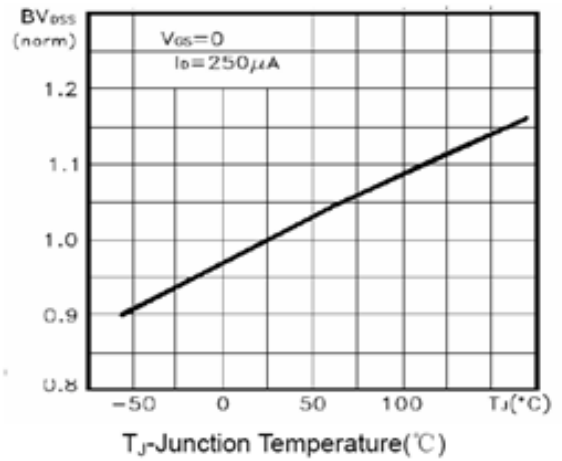

Figure 9 BV_{DSS} vs Junction Temperature

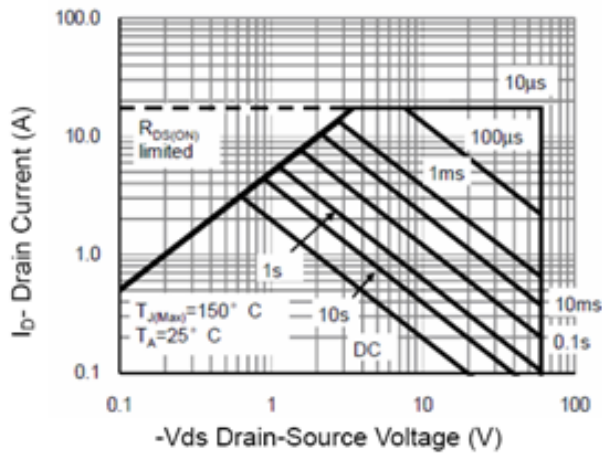

Figure 8 Safe Operation Area

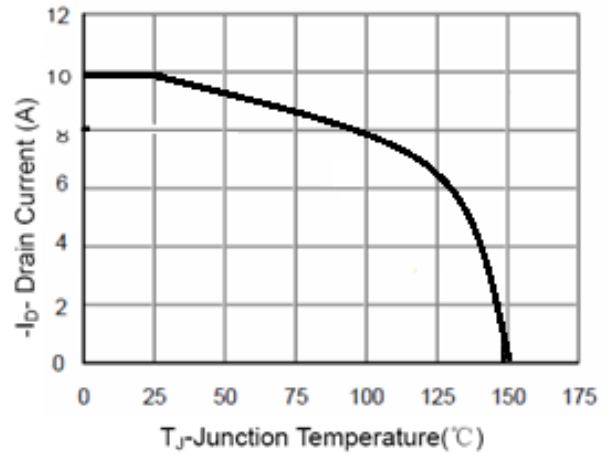

Figure 10 I_D Current De-rating

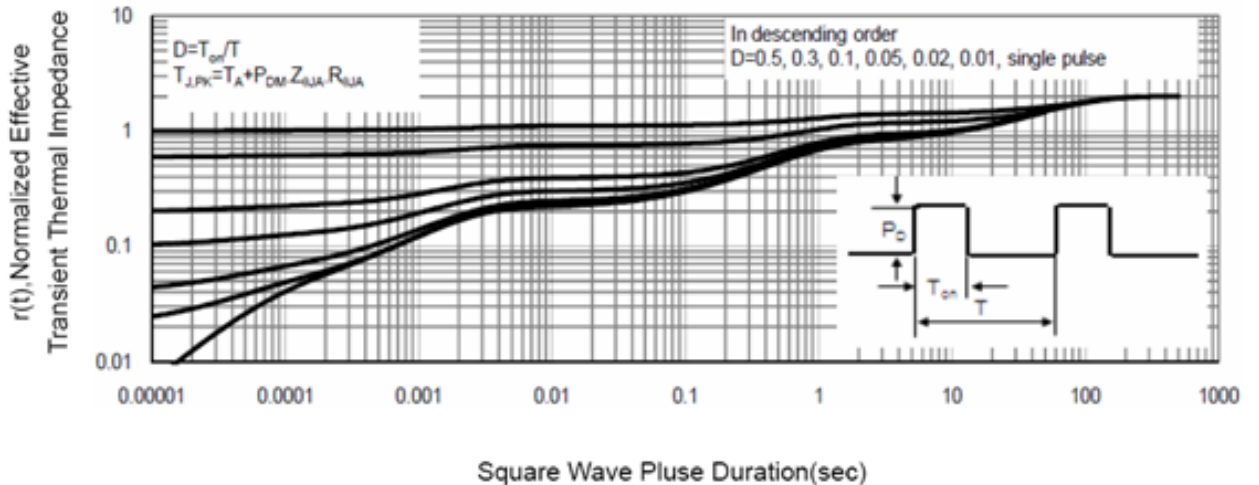

Figure 11 Normalized Maximum Transient Thermal Impedance